

Achievable Regions for Interference Channels with Generalized and Intermittent Feedback

Abdellatif Zaidi [†]

[†] Université Paris-Est Marne La Vallée, Champs-sur-Marne 77454, France
abdellatif.zaidi@univ-mlv.fr

Abstract—In this paper, we first study a two-user interference channel with generalized feedback. We establish an inner bound on its capacity region. The coding scheme that we employ for the inner bound is based on an appropriate combination of Han-Kobayashi rate splitting and compress-and-forward at the senders. Each sender compresses the channel output that it observes using a compression scheme that is à-la Lim *et al.* noisy network coding and Avestimeher *et al.* quantize-map-and-forward. Next, we study an injective deterministic model in which the senders obtain output feedback only intermittently. Specializing the coding scheme of the model with generalized feedback to this scenario, we obtain useful insights onto effective ways of combining noisy network coding with interference alignment techniques. We also show that the resulting coding scheme is optimal for linear deterministic interference channels with intermittent feedback.

I. INTRODUCTION

The interference channel (IC) models situations in which separate senders communicate with distinct destinations over a common channel. In this model, the signal transmitted by one sender constitutes interference in the eyes of other sender-receiver pairs. The study of the IC was initiated by Shannon [1] and further studied by Ahlswede [2] and Carleial [3]. The capacity region of the IC is still unknown, and the best achievable rate region to date is due to Han and Kobayashi [4].

It is well known that feedback does not increase the capacity in memoryless point-to-point communication channels. However, feedback can enlarge the capacity in multiuser channels by enabling statistical cooperation among the transmitters (see, e.g., [5] and references therein). For interference networks with feedback, the choice of an appropriate form of users cooperation for managing interference depends highly on the quality of feedback signals that the transmitters get. For example, when the feedback is perfect or noiseless users can perform partial decode-and-forward or variants of it; and this offers substantial rate gains. In this case, capacity gains can even be unbounded if the feedback is free of cost [6]. Partial decode-and-forward type cooperation can also be exploited for managing interference in certain noisy feedback settings [7]. For other settings, impairments on the feedback links may render the feedback signals so weak that requiring each transmitter to decode all or part of other users messages may only lead to stringent rate constraints. In such settings, schemes in which senders perform compressions of the observed feedback signals may be more appropriate.

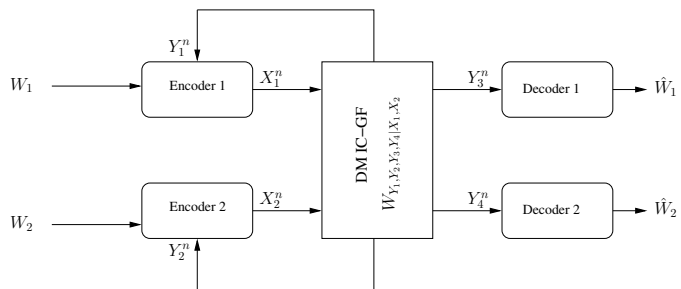

Fig. 1. Memoryless interference channel with generalized feedback (IC-GF) with two source-destination pairs.

In this paper, we first study a two-user memoryless interference channel with *generalized feedback* (IC-GF). We establish an inner bound on its capacity region. The coding scheme that we employ for the proof of the inner bound is based on an appropriate combination of Block-Markov coding, Han-Kobayashi rate-splitting [4] and compression at the encoders [8]. An important ingredient of the coding scheme is how the compression is performed at the encoders. Note that since the destinations generally observe distinct outputs signals, for this model compressions that perform binning at the encoders and unique decoding of the compression indices, i.e., à-la Wyner-Ziv [9], may result in rates that are limited by the worst side information. For this reason, two important features of the compression in our coding scheme are 1) standard compression without Wyner-Ziv binning and 2) non-explicit decoding of the compression indices. That is, the compression is à-la Lim *et al.* noisy network coding [10] or Avestimeher *et al.* quantize-map-and-forward [11].

Next, we apply the results to a model in which the encoders get perfect feedback, but *only intermittently*. That is, at each time instant, each encoder either observes the previous channel output of its corresponding receiver or an erasure symbol, depending on a binary valued state variable. Aspects of intermittence have been studied in some related works in the literature, such as for a linear deterministic interference channel in [12], [13] and for a multiaccess channel in [14]. By specializing the aforementioned inner bound to this model, we show that the scheme reduces to one in which noisy-network coding is combined appropriately with interference alignment. We also study a linear deterministic model and show that the inner bound is tight in the case, thereby re-establishing a result previously obtained by Karakus *et al.*

[12].

II. PROBLEM SETUP

Consider the two sender-receiver (2-user) pair discrete memoryless interference channel with generalized feedback IC-GF $(\mathcal{X}_1 \times \mathcal{X}_2, p(y_1, y_2, y_3, y_4 | x_1, x_2), \mathcal{Y}_1 \times \mathcal{Y}_2 \times \mathcal{Y}_3 \times \mathcal{Y}_4)$ shown in Figure 1. It consists of two input alphabets $\mathcal{X}_1, \mathcal{X}_2$, four output alphabets $\mathcal{Y}_1, \mathcal{Y}_2, \mathcal{Y}_3$ and \mathcal{Y}_4 , and a collection of conditional probability mass functions $p(y_1, y_2, y_3, y_4 | x_1, x_2)$ on $\mathcal{Y}_1 \times \mathcal{Y}_2 \times \mathcal{Y}_3 \times \mathcal{Y}_4$. All input and output alphabets are assumed to be finite. Source $k, k = 1, 2$, has a message W_k that it wants to transmit to Destination k . The messages W_1 and W_2 are independent random variables drawn uniformly from the sets $\mathcal{W}_1 = \{1, \dots, M_1\}$ and $\mathcal{W}_2 = \{1, \dots, M_2\}$, respectively. The channel is modeled as a memoryless conditional probability distribution $W_{Y_1, Y_2, Y_3, Y_4 | X_1, X_2}$ so that the law governing n -sequences of output letters is

$$P_{Y_1^n, Y_2^n, Y_3^n, Y_4^n | X_1^n, X_2^n}(y_1^n, y_2^n, y_3^n, y_4^n | x_1^n, x_2^n) = \prod_{i=1}^n W_{Y_1, Y_2, Y_3, Y_4 | X_1, X_2}(y_{1,i}, y_{2,i}, y_{3,i}, y_{4,i} | x_{1,i}, x_{2,i}). \quad (1)$$

Receiver $k, k = 1, 2$, guesses the message W_k that is intended to it using its channel output Y_{k+2}^n .

Definition 1: For positive integers n, M_1 and M_2 , an (M_1, M_2, n, ϵ) code for the interference channel with generalized feedback consists of sequences of encoder mappings

$$\phi_{k,i} : \mathcal{W}_k \times \mathcal{Y}_k^{i-1} \longrightarrow \mathcal{X}_k, \quad k = 1, 2, \quad i = 1, \dots, n \quad (2)$$

and decoding maps

$$\psi_k : \mathcal{Y}_{k+2}^n \longrightarrow \mathcal{W}_k, \quad k = 1, 2 \quad (3)$$

such that the maximum probability of error among the two decoders does not exceed ϵ ,

$$\max_{k \in \{1, 2\}} \Pr[\hat{W}_k \neq W_k] \leq \epsilon \quad (4)$$

The rate of messages W_1 and W_2 are defined as

$$R_1 = \frac{1}{n} \log M_1 \quad \text{and} \quad R_2 = \frac{1}{n} \log M_2,$$

respectively. A rate pair (R_1, R_2) is said to be achievable if for every $\epsilon > 0$ there exists an $(2^{nR_1}, 2^{nR_2}, n, \epsilon)$ code for the channel $W_{Y_1, Y_2, Y_3, Y_4 | X_1, X_2}$. The capacity region $\mathcal{C}_{\text{ic-gf}}$ of the interference channel with generalized feedback (IC-GF) is defined as the closure of the set of achievable rate pairs.

Due to space limitation, the results of this paper are either outlined only or mentioned without proofs. Detailed proofs can be found in [15].

III. INTERFERENCE CHANNEL WITH GENERALIZED FEEDBACK

A. Inner Bound

Let $\mathcal{R}_{\text{ic-gf}}^{\text{in}}$ stand for the collection of all random variables $(Q, U_1, V_1, U_2, V_2, X_1, X_2, Y_1, Y_2, Y_3, Y_4)$ such that $Q, U_1, V_1, U_2,$

V_2, X_1 and X_2 take values in finite alphabets $\mathcal{Q}, \mathcal{U}_1, \mathcal{V}_1, \mathcal{U}_2, \mathcal{V}_2, \mathcal{X}_1$ and \mathcal{X}_2 , respectively, and satisfy

$$\begin{aligned} & P_{Q, U_1, V_1, U_2, V_2, X_1, X_2, Y_1, Y_2, Y_3, Y_4}(q, u_1, v_1, u_2, v_2, x_1, x_2, y_1, y_2, y_3, y_4) \\ &= P_Q(q) P_{U_1, X_1 | Q}(u_1, x_1 | q) P_{U_2, X_2 | Q}(u_2, x_2 | q) P_{V_1 | U_1, Y_1, Q}(v_1 | u_1, y_1, q) \\ & \cdot P_{V_2 | U_2, Y_2, Q}(v_2 | u_2, y_2, q) W_{Y_1, Y_2, Y_3, Y_4 | X_1, X_2}(y_1, y_2, y_3, y_4 | x_1, x_2). \end{aligned} \quad (5)$$

The relations in (5) imply that $V_1 \leftrightarrow U_1 \leftrightarrow X_1, V_2 \leftrightarrow U_2 \leftrightarrow X_2$ and $(U_1, U_2, V_1, V_2) \leftrightarrow (X_1, X_2) \leftrightarrow (Y_1, Y_2, Y_3, Y_4)$ are Markov chains; X_1 is independent of Y_1 and X_2 is independent of Y_2 .

Define $\mathcal{R}_{\text{ic-gf}}^{\text{in}}$ to be the set of all rate pairs (R_1, R_2) such that there exist non-negative numbers R_{10}, R_{20} satisfying

$$R_1 \leq I(U_1, V_1, X_1; Y_3 | U_2, V_2, Q) - I(V_1; Y_1 | U_1, Q) \quad (6a)$$

$$R_1 + R_{20} \leq I(U_1, V_1, U_2, V_2, X_1; Y_3 | Q) - I(V_1; Y_1 | U_1, Q) - I(V_2; Y_2 | U_2, Q) \quad (6b)$$

$$R_1 - R_{10} + R_{20} \leq \min\{I(U_1, V_1, U_2, V_2, X_1; Y_3 | Q) - I(V_1; Y_1 | U_1, Q), I(U_2, V_2, X_1; Y_3 | U_1, V_1, Q)\} - I(V_2; Y_2 | U_2, Q) \quad (6c)$$

$$R_1 - R_{10} \leq \min\{I(U_1, V_1, X_1; Y_3 | U_2, V_2, Q), I(U_2, V_2, X_1; Y_3 | U_1, V_1, Q)\} - I(V_1; Y_1 | U_1, Q) - I(V_2; Y_2 | U_2, Q) \quad (6d)$$

$$R_1 - R_{10} \leq I(X_1; Y_3 | U_1, V_1, U_2, V_2, Q) \quad (6e)$$

$$R_2 \leq I(U_2, V_2, X_2; Y_4 | U_1, V_1, Q) - I(V_2; Y_2 | U_2, Q) \quad (6f)$$

$$R_2 + R_{10} \leq I(U_1, V_1, U_2, V_2, X_2; Y_4 | Q) - I(V_1; Y_1 | U_1, Q) - I(V_2; Y_2 | U_2, Q) \quad (6g)$$

$$R_2 - R_{20} + R_{10} \leq \min\{I(U_1, V_1, U_2, V_2, X_2; Y_4 | Q) - I(V_2; Y_2 | U_2, Q), I(U_1, V_1, X_2; Y_4 | U_2, V_2, Q)\} - I(V_1; Y_1 | U_1, Q) \quad (6h)$$

$$R_2 - R_{20} \leq \min\{I(U_2, V_2, X_2; Y_4 | U_1, V_1, Q), I(U_1, V_1, X_2; Y_4 | U_2, V_2, Q)\} - I(V_1; Y_1 | U_1, Q) - I(V_2; Y_2 | U_2, Q) \quad (6i)$$

$$R_2 - R_{20} \leq I(X_2; Y_4 | U_1, V_1, U_2, V_2, Q) \quad (6j)$$

for some joint distribution of the form (5).

Theorem 1: The capacity region of the interference channel with generalized feedback satisfies

$$\mathcal{R}_{\text{ic-gf}}^{\text{in}} \subseteq \mathcal{C}_{\text{ic-gf}}. \quad (7)$$

Proof: An outline proof of the coding scheme that we use for the proof of Theorem 1 is given in Section V. The associated error analysis may be found in [15].

B. Comments

Remark 1: The proof of Theorem 1 is based on a Block-Markov coding scheme in which each encoder sends a compressed version of its output observation to the receivers, in addition to public and private messages obtained through rate splitting à-la Han-Kobayashi [4]. A key ingredient of our coding scheme is how the compression is performed at the encoders. Note that since the destinations generally observe distinct outputs signals, for this model compressions that perform binning at the encoders and unique decoding of the compression indices, i.e., à-la Wyner-Ziv [9], may result in rates that are limited by the worst side information. For this reason, two important features of the compression in our coding scheme are 1) standard compression without Wyner-Ziv binning and 2) non-explicit decoding of the compression

indices. That is, the compression is à-la Lim *et al.* noisy network coding [10] or Avestimeher *et al.* quantize-map-and-forward [11]. More precisely, unlike the original compress-and-forward scheme by Cover and El Gamal [8] where every information message is divided into blocks and different submessages are sent over these blocks and then decoded one at a time using the same codebook, here the *entire* public and private messages are retransmitted over *all* blocks using codebooks that are generated independently, one for each block, and the decoding is performed simultaneously using all blocks. Also, like [10] and [11], at each block the compression index of the output that is observed at the previous block is sent using standard rate distortion, not Wyner-Ziv binning. At the end of the transmission, Receiver k , $k = 1, 2$, uses its output from all blocks to perform simultaneous decoding of the public message w_{k0} and private message w_{kk} , without uniquely decoding neither the public message sent by the respective encoder nor the compression indices.

Remark 2: In (11), the random variable Q serves as a time sharing random variable; the random variable U_k , $k = 1, 2$, carries the public message W_{k0} sent by Encoder k and the random variable V_k carries a compression of the output Y_k . The transmission takes place in B blocks. The message W_k , $k = 1, 2$, is divided into independent parts, a public message W_{k0} , sent at rate R_{k0} , and a private message W_{kk} , sent at rate R_{kk} . At the beginning of block i , $i = 1, \dots, B$, Encoder k , $k = 1, 2$, does not compress only the output $y_k[i-1]$ that is has observed in block $i-1$, but also a compression of the part of its input of the last block that carries the public message. More precisely, denote by $\mathbf{u}_k[i-1] := \mathbf{u}_{k,i-1}(w_{k0}, t_{k,i-2})$ the part of the input of Encoder k that is sent in block $i-1$ and carries the public message w_{k0} as well as the compression index $t_{k,i-2}$ of the output $y_k[i-2]$. In block i , Encoder k first looks for an appropriate compression index $t_{k,i-1}$ of $(\mathbf{u}_k[i-1], \mathbf{y}_k[i-1])$, and then sends $\mathbf{x}_{k,i}[i] := \mathbf{x}_{k,i}(w_{k0}, t_{k,i-1}, w_{kk})$ generated on top of $\mathbf{u}_k[i] := \mathbf{u}_{k,i}(w_{k0}, t_{k,i-1})$. That is, the private message w_{kk} is superimposed on top of the compression index $t_{k,i-1}$, which itself is superimposed on top of the public message w_{k0} . At the end of the transmission, Decoder k , $k = 1, 2$, has collected all its outputs $(y_k[1], y_k[2], \dots, y_k[B])$ from which it decodes jointly the pair (w_{k0}, w_{kk}) of public and private messages transmitted by the respective encoder, i.e., Encoder k , without uniquely decoding neither the compression indices from both encoders nor the public message from the other encoder.

IV. INJECTIVE DETERMINISTIC IC WITH INTERMITTENT FEEDBACK

Consider the deterministic interference channel depicted in Figure 2. The channel outputs are given by

$$Y_3 = f_3(X_1, T_2) \quad \text{and} \quad Y_4 = f_4(X_2, T_1) \quad (8)$$

where $T_1 = t_1(X_1)$ and $T_2 = t_2(X_2)$ are functions of X_1 and X_2 , respectively. We assume that the functions f_3 and f_4 are injective in t_2 and t_1 , respectively. That is, for every $x_1 \in \mathcal{X}_1$, $f_3(x_1, t_2)$ is a one-to-one function of t_2 , and for every $x_2 \in \mathcal{X}_2$, $f_4(x_2, t_1)$ is a one-to-one function of t_1 . This class of interference channels is motivated by noiseless Gaussian IC, where the functions f_3 and f_4 are additions.

There are two feedback links, from Decoder 1 to Encoder 1 and from Decoder 2 to Encoder 2. We associate a state sequence S_k^n , $k = 1, 2$, with the feedback link from Decoder k to Encoder k . The feedback state sequences are possibly correlated, with

$$p_{S_1^n, S_2^n}(s_1^n, s_2^n) = \prod_{i=1}^n p_{S_1, S_2}(s_{1i}, s_{2i}). \quad (9)$$

Let $\{S_k[i] = 1\}$, $k = 1, 2$, $i = 1, \dots, n$, denote the feedback event in the feedback link from Decoder k to Encoder k at time i , i.e., $Y_k[i] = Y_{k+2}[i]$ — (the event $\{S_k[i] = *\}$ then denotes erasure in this feedback link at time i). We assume that

$$\Pr(S_1 = 1) = p_1 \quad \text{and} \quad \Pr(S_2 = 1) = p_2 \quad (10)$$

and that the state sequences are revealed in a strictly causal manner to *both* encoders.

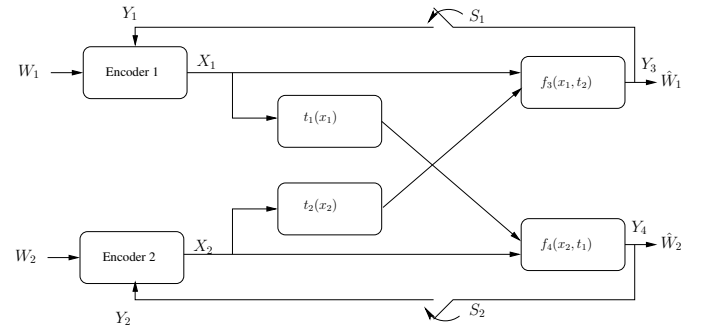

Fig. 2. Injective deterministic IC with intermittent feedback. Erasures in the feedback link from Decoder k to encoder k , $k = 1, 2$, are governed by the state sequence S_k^n .

The input signal from Encoder k , $k = 1, 2$, at time i , $i = 1, \dots, n$, can depend on all the past observations at the encoder, i.e., $X_k[i] = \phi_{k,i}(W_k, S_1^{i-1}, S_2^{i-1}, Y_k^{i-1})$. After n channel uses, Decoder k , $k = 1, 2$, guesses an estimate \hat{W}_k of message W_k from its output Y_{k+2}^n .

A. Inner Bound

For convenience, we assume that $*0 = *1 = *$. Let, for $k = 1, 2$, $\tilde{Y}_k = S_k \cdot Y_k$. At time i , we have $\tilde{Y}_k[i] = S_k[i] \cdot Y_k[i]$. Thus, $\tilde{Y}_k[i] = Y_k[i]$ if $S_k[i] = 1$ and $\tilde{Y}_k[i] = *$ if $S_k[i] = *$. With these notations, we have that, at time i , $i = 2, \dots, n$, Encoder k gets $\tilde{Y}_k[i-1]$ by means of the intermittent feedback from Decoder k . Also, define $\tilde{T}_1 = S_2 \cdot T_1$ and $\tilde{T}_2 = S_1 \cdot T_2$. At time i , $\tilde{T}_1[i] = T_1[i]$ if $S_2[i] = 1$ and $\tilde{T}_1[i] = *$ if $S_2[i] = *$. Similarly, $\tilde{T}_2[i] = T_2[i]$ if $S_1[i] = 1$ and $\tilde{T}_2[i] = *$ if $S_1[i] = *$. Then, it is easy to see that because the function f_3 is injective in t_2 for every x_1 , at time i , $i = 1, \dots, n$, Encoder 1 gets also knows $\tilde{T}_2[i-1]$. Similarly, because the function f_4 is injective in t_1 for every x_2 , at time i Encoder 2 knows $\tilde{T}_1[i-1]$. Thus, at time i each encoder knows both $\tilde{T}_1[i-1]$ and $\tilde{T}_2[i-1]$. Let $\tilde{T} = (\tilde{T}_1, \tilde{T}_2) = (S_2 T_1, S_1 T_2)$. The above means that, at time i , both encoders know the value of the pair $\tilde{T}[i-1] = (\tilde{T}_1[i-1], \tilde{T}_2[i-1])$.

Applying the coding scheme of Theorem 1 with the choice $Y := Y_1 = Y_2 = \tilde{T} = (S_2 T_1, S_1 T_2)$, $U_1 = T_1$ and $U_2 = T_2$ we get the achievable region that will follows for the injective deterministic IC with intermittent feedback.

Define $\mathcal{R}_{\text{ic-if}}^{\text{in}}$ to be the set of all rate pairs (R_1, R_2) such that there exist non-negative numbers R_{10}, R_{20} satisfying

$$R_1 \leq H(Y_3|T_2, V_2, Q) - I(V_1; Y|T_1, Q) \quad (11a)$$

$$R_1 + R_{20} \leq H(Y_3|Q) - I(V_1; Y|T_1, Q) - I(V_2; Y|T_2, Q) \quad (11b)$$

$$R_1 - R_{10} + R_{20} \leq \min\{H(Y_3|Q) - I(V_1; Y|T_1, Q), H(Y_3|T_1, V_1, Q)\} - I(V_2; Y|T_2, Q) \quad (11c)$$

$$R_1 - R_{10} \leq \min\{H(Y_3|T_2, V_2, Q), H(Y_3|T_1, V_1, Q)\} - I(V_1; Y|T_1, Q) - I(V_2; Y|T_2, Q) \quad (11d)$$

$$R_1 - R_{10} \leq H(Y_3|T_1, V_1, T_2, V_2, Q) \quad (11e)$$

$$R_2 \leq H(Y_4|T_1, V_1, Q) - I(V_2; Y|T_2, Q) \quad (11f)$$

$$R_2 + R_{10} \leq H(Y_4|Q) - I(V_1; Y|T_1, Q) - I(V_2; Y|T_2, Q) \quad (11g)$$

$$R_2 - R_{20} + R_{10} \leq \min\{H(Y_4|Q) - I(V_2; Y|T_2, Q), H(Y_4|T_2, V_2, Q)\} - I(V_1; Y|T_1, Q) \quad (11h)$$

$$R_2 - R_{20} \leq \min\{H(Y_4|T_1, V_1, Q), H(Y_4|T_2, V_2, Q)\} - I(V_1; Y|T_1, Q) - I(V_2; Y|T_2, Q) \quad (11i)$$

$$R_2 - R_{20} \leq H(Y_4|T_1, V_1, T_2, V_2, Q). \quad (11j)$$

for some joint distribution of the form (5).

Theorem 2: The capacity region of the injective deterministic interference channel with intermittent feedback satisfies

$$\mathcal{R}_{\text{ic-if}}^{\text{in}} \subseteq C_{\text{ic-if}}. \quad (12)$$

Remark 3: Note that $T_1[i-1]$ is the interference that Transmitter 1 causes to Receiver 2 at time $i-1$. However, because the feedback from Decoder 2 is intermittent, at time i this interference is seen by Encoder 2 as if it were (only) $\tilde{T}_1[i-1]$. Similarly, the interference $T_2[i-1]$ is seen by Encoder 1 at time i as if it were (only) $\tilde{T}_2[i-1]$. With the choice $V_1[i] = V_2[i] = (\tilde{T}_1[i-1], \tilde{T}_2[i-1])$, the coding scheme of Theorem 2 – (which, as we mentioned previously, is an instantiation of that of Theorem 1 to the injective deterministic model) can be viewed as an *appropriate*, non-trivial, combination of Lim *et al.* noisy network coding [10] or Avestimeher *et al.* quantize-map-and-forward [11] and the technique of interference alignment.

B. Capacity Region of Linear Deterministic IC with Intermittent Feedback

In this section, we study an important special class of injective interference channels with intermittent feedback: the linear deterministic model [11] with intermittent feedback. Here, $\mathcal{X}_1 = \mathcal{X}_2 = \mathbb{F}_2^q$. The input-output relations at time i , $i = 1, \dots, n$, are given by

$$\mathbf{Y}_3[i] = \mathbf{H}_{11}\mathbf{X}_1[i] + \mathbf{H}_{12}\mathbf{X}_2[i], \quad \mathbf{Y}_4[i] = \mathbf{H}_{22}\mathbf{X}_2[i] + \mathbf{H}_{21}\mathbf{X}_1[i] \quad (13)$$

where $\mathbf{X}_k[i]$, $k = 1, 2$, are binary vectors of length q denoting the transmitted signals at time (or block i); $\mathbf{Y}_{k+2}[i]$, $k = 1, 2$, are binary vectors of same length denoting the received signals; channel matrices $(\mathbf{H}_{11}, \mathbf{H}_{12}, \mathbf{H}_{21}, \mathbf{H}_{22})$ are such that, for $(k, l) \in \{1, 2\}^2$, $\mathbf{H}_{kl} = \mathbf{H}^{q-n_{kl}}$ with \mathbf{H} denoting the $q \times q$ shift matrix and n_{kl} are nonnegative numbers whose values are related to the channel gains. The summation in (13) is in \mathbb{F}_2 (modulo 2).

The inner bound of Theorem 2 is optimal for the linear deterministic model (13) with intermittent feedback, a channel

whose capacity region has been fully characterized recently in [12, Theorem 3.1]. The coding scheme of Theorem 2 then provides an alternate optimal coding for the model (13).

Define C be the set of all rate pairs (R_1, R_2) satisfying

$$R_1 \leq \min \{ \max(n_{11}, n_{12}), n_{11} + p_2(n_{21} - n_{11})^+ \} \quad (14a)$$

$$R_2 \leq \min \{ \max(n_{22}, n_{21}), n_{22} + p_1(n_{12} - n_{22})^+ \} \quad (14b)$$

$$R_1 + R_2 \leq \min \left\{ \max(n_{11}, n_{12}) + (n_{22} - n_{12})^+, \max(n_{22}, n_{21}) + (n_{11} - n_{21})^+ \right\} \quad (14c)$$

$$R_1 + R_2 \leq \max \left\{ n_{12}, (n_{11} - n_{21})^+ \right\} + \max \left\{ n_{21}, (n_{22} - n_{12})^+ \right\} + p_1 \min \left\{ n_{12}, (n_{11} - n_{21})^+ \right\} + p_2 \min \left\{ n_{21}, (n_{22} - n_{12})^+ \right\} \quad (14d)$$

$$2R_1 + R_2 \leq \max(n_{11}, n_{12}) + \max \left\{ n_{21}, (n_{22} - n_{12})^+ \right\} + (n_{11} - n_{21})^+ + p_2 \min \left\{ n_{21}, (n_{22} - n_{12})^+ \right\} \quad (14e)$$

$$R_1 + 2R_2 \leq \max(n_{22}, n_{21}) + \max \left\{ n_{12}, (n_{11} - n_{21})^+ \right\} + (n_{22} - n_{12})^+ + p_1 \min \left\{ n_{12}, (n_{11} - n_{21})^+ \right\}. \quad (14f)$$

As stated [12, Theorem 3.1], the set C characterizes the capacity region of the linear deterministic interference channel with intermittent feedback (13).

Theorem 3: The inner bound of Theorem 2 is optimal for the linear deterministic model (13) with intermittent feedback, whose capacity region is given by C .

Remark 4: The coding scheme of Theorem 2 (which, itself, can be obtained as an instance of that of Theorem 1) is more general than that of [12]. At high level, however, the two coding schemes share elements, in that the interferences are aligned, compressed and then conveyed to the receivers. However, there are substantial differences, including for example the compression which is based on Wyner-Ziv binning in [12] and on standard compression in this paper. Also, by opposition to [12] the compression indices are not uniquely decoded here; and simultaneous decoding is employed instead of backward decoding.

V. PROOF OF ACHIEVABILITY (THEOREM 1)

For convenience, we consider the case $Q = \emptyset$. Achievability for an arbitrary time-sharing random variable Q can be proved using the coded time-sharing technique [16].

As we mentioned previously, the transmission takes place in B blocks. Also, message W_k , $k = 1, 2$, is divided into a “public” message W_{k0} that is sent at rate R_{k0} and a “private” message W_{kk} that is sent at rate R_{kk} . The total rate for message W_k is then $R_k = R_{k0} + R_{kk}$. The messages $(W_{10}, W_{11}, W_{20}, W_{22})$ are sent over *all* blocks. We thus have $B_{W_{k0}} = nBR_{k0}$, $B_{W_{kk}} = nBR_{kk}$, $N = nB$, $R_{W_{k0}} = B_{W_{k0}}/N = R_{k0}$ and $R_{W_{kk}} = B_{W_{kk}}/N = R_{kk}$, where $B_{W_{k0}}$ is the number of public message W_{k0} bits, $B_{W_{kk}}$ is the number of private message W_{kk} bits, N is the total number of channel uses (over B blocks) and $R_{W_{k0}}$ and $R_{W_{kk}}$ are the overall rates of the public message W_{k0} and private message W_{kk} , respectively.

Codebook Generation: Fix a measure $P_{U_1, V_1, U_2, V_2, X_1, X_2, Y_1, Y_2, Y_3, Y_4} \in \mathcal{P}_{\text{ic-gf}}^{\text{in}}$. Fix $\epsilon > 0$, $\eta_{10} > 0$, $\eta_{11} > 0$,

$\eta_{20} > 0, \eta_{22} > 0, \delta_1 > 0, \delta_2 > 0$ and denote $M_{10} = 2^{nB[R_{10}-\eta_{10}\epsilon]}$, $M_{11} = 2^{nB[R_{11}-\eta_{11}\epsilon]}$, $M_{20} = 2^{nB[R_{20}-\eta_{20}\epsilon]}$, $M_{22} = 2^{nB[R_{22}-\eta_{22}\epsilon]}$, $\hat{M}_1 = 2^{n[\hat{R}_1+\delta_1\epsilon]}$ and $\hat{M}_2 = 2^{n[\hat{R}_2+\delta_2\epsilon]}$.

We randomly and independently generate a codebook for each block.

- 1) For each block $i, i = 1, \dots, B$, we generate $M_{10}\hat{M}_1$ independent and identically distributed (i.i.d.) codewords $\mathbf{u}_{1,i}(w_{10}, t'_{1,i})$ indexed by $w_{10} = 1, \dots, M_{10}, t'_{1,i} = 1, \dots, \hat{M}_1$, each with i.i.d. components drawn according to P_{U_1} . Similarly, for each block $i, i = 1, \dots, B$, we generate $M_{20}\hat{M}_2$ independent and identically distributed (i.i.d.) codewords $\mathbf{u}_{2,i}(w_{20}, t'_{2,i})$ indexed by $w_{20} = 1, \dots, M_{20}, t'_{2,i} = 1, \dots, \hat{M}_2$, each with i.i.d. components drawn according to P_{U_2} .
- 2) For each block i , for each codeword $\mathbf{u}_{1,i}(w_{10}, t'_{1,i})$, we generate \hat{M}_1 i.i.d. codewords $\mathbf{v}_{1,i}(w_{10}, t'_{1,i}, t_{1,i})$ indexed by $t_{1,i} = 1, \dots, \hat{M}_1$, each with i.i.d. components drawn according to $P_{V_1|U_1}$. Similarly, for each block i , for each codeword $\mathbf{u}_{2,i}(w_{20}, t'_{2,i})$, we generate \hat{M}_2 i.i.d. codewords $\mathbf{v}_{2,i}(w_{20}, t'_{2,i}, t_{2,i})$ indexed by $t_{2,i} = 1, \dots, \hat{M}_2$, each with i.i.d. components drawn according to $P_{V_2|U_2}$.
- 3) For each block i , for each codeword $\mathbf{u}_{1,i}(w_{10}, t'_{1,i})$, we generate M_1 i.i.d. codewords $\mathbf{x}_{1,i} = (w_{10}, t'_{1,i}, w_{11})$ indexed by $w_{11} = 1, \dots, M_1$, each with i.i.d. components draw according to $P_{X_1|U_1}$. Similarly, for each block i , for each codeword $\mathbf{u}_{2,i}(w_{20}, t'_{2,i})$, we generate M_2 i.i.d. codewords $\mathbf{x}_{2,i} = (w_{20}, t'_{2,i}, w_{22})$ indexed by $w_{22} = 1, \dots, M_2$, each with i.i.d. components draw according to $P_{X_2|U_2}$.

Encoding: Suppose that a message pair (W_1, W_2) are to be transmitted, with $W_1 = (w_{10}, w_{11})$ and $W_2 = (w_{20}, w_{22})$. As we mentioned previously, (w_{10}, w_{11}) and (w_{20}, w_{22}) will be sent over *all* blocks. We denote by $\mathbf{y}_k[i-1], k = 1, 2, i = 1, \dots, B$, the GF output observed by Encoder k in block i . For convenience, we let $\mathbf{y}_1[0] = \emptyset$ and $t_{1,-1} = t_{1,0} = 1$ (a default value). Similarly, we let $\mathbf{y}_2[0] = \emptyset$ and $t_{2,-1} = t_{2,0} = 1$. The encoding at the beginning of block $i, i = 1, \dots, B$, is as follows.

Encoder 1 which has observed the GF output $\mathbf{y}_1[i-1]$, knows $t_{1,i-2}$ and looks for a compression index $t_{1,i-1} \in [1 : \hat{M}_1]$ such that $\mathbf{v}_{1,i-1}(w_{10}, t_{1,i-2}, t_{1,i-1})$ is strongly jointly typical with $\mathbf{y}_1[i-1]$ and $\mathbf{u}_{1,i-1}(w_{10}, t_{1,i-2})$. If there is no such index or the GF output $\mathbf{y}_1[i-1]$ is not typical, $t_{1,i-1}$ is set to 1 and an error is declared. If there is more than one such index $t_{1,i-1}$, choose the smallest. One can show that the encoding error in this step is small as long as n large and

$$\hat{R}_1 > I(V_1; Y_1|U_1). \quad (15)$$

Encoder 1 transmits the vector $\mathbf{x}_{1,i}(w_{10}, t_{1,i-1}, w_{11})$. Similarly, Encoder 2 finds the appropriate compression index $t_{2,i-1}$ as long as n large and

$$\hat{R}_2 > I(V_2; Y_2|U_2). \quad (16)$$

Encoder 2 then transmits the vector $\mathbf{x}_{2,i}(w_{20}, t_{2,i-1}, w_{22})$.

Decoding: We use simultaneous nonunique decoding. At the end of the transmission, Decoder 1 has collected all the blocks of channel outputs $(\mathbf{y}_3[1], \dots, \mathbf{y}_3[B])$ and Decoder 2 has collected all the blocks of channel outputs $(\mathbf{y}_4[1], \dots, \mathbf{y}_4[B])$.

Decoder 1 estimates the pair (w_{10}, w_{11}) using all blocks $i = 1, \dots, B$, i.e., simultaneous joint decoding. It finds the unique $(\hat{w}_{10}, \hat{w}_{11})$ s.t. $\mathbf{u}_{1,i}(\hat{w}_{10}, t_{1,i-1}), \mathbf{v}_{1,i}(\hat{w}_{10}, t_{1,i-1}, t_{1,i}), \mathbf{x}_{1,i}(\hat{w}_{10}, t_{1,i-1}, w_{1,1}), \mathbf{u}_{2,i}(w_{20}, t_{2,i-1}), \mathbf{v}_{2,i}(w_{20}, t_{2,i-1}, t_{2,i}), \mathbf{y}_3[i]$ are jointly typical for all $i = 1, \dots, B$, for some $w_{20} \in [1, M_{20}]$; otherwise it declares an error. One can show that Decoder 1 obtains the correct (w_{10}, w_{11}) as long as n and B are large and

$$R_{11} + R_{10} + \hat{R}_1 \leq I(U_1, V_1, X_1; Y_3|U_2, V_2) \quad (17a)$$

$$R_{11} + R_{10} + \hat{R}_1 + \hat{R}_2 \leq I(U_1, V_1, U_2, V_2, X_1; Y_3) \quad (17b)$$

$$R_{11} + R_{10} + R_{20} + \hat{R}_1 + \hat{R}_2 \leq I(U_1, V_1, U_2, V_2, X_1; Y_3) \quad (17c)$$

and

$$R_{11} \leq I(X_1; Y_3|U_1, V_1, U_2, V_2) \quad (18a)$$

$$R_{11} + R_{20} + \hat{R}_2 \leq I(U_2, V_2, X_1; Y_3|U_1, V_1) \quad (18b)$$

$$R_{11} + \hat{R}_1 + \hat{R}_2 \leq I(U_1, V_1, X_1; Y_3|U_2, V_2) \quad (18c)$$

$$R_{11} + \hat{R}_1 + \hat{R}_2 \leq I(U_2, V_2, X_1; Y_3|U_1, V_1) \quad (18d)$$

$$R_{11} + R_{20} + \hat{R}_1 + \hat{R}_2 \leq I(U_1, V_1, U_2, V_2, X_1; Y_3). \quad (18e)$$

Similarly, Decoder 2 finds the correct pair (w_{20}, w_{22}) if similar constraints that are obtained by swapping the indices 1 and 2 and substituting the index 3 with 4 in (17) and (18).

REFERENCES

- [1] C. E. Shannon, "Two-way communication channels," in *Proc. of 4th Berkeley Symp. Mathematical Statistics and Probability*, vol. 1, Berkeley, CA, 1961, pp. 611–644.
- [2] R. Ahlswede, "The capacity region of a channel with two senders and two receivers," *Annals of Probability*, vol. 2, pp. 805–814, 1974.
- [3] A. B. Carleial, "Interference channels," *IEEE Trans. Inf. Theory*, vol. 24, pp. 60–70, 1978.
- [4] T. S. Han and K. Kobayashi, "A new achievable rate region for the interference channel," *IEEE Trans. Inf. Theory*, vol. 27, pp. 49–60, 1981.
- [5] G. Dueck, "Partial feedback for two-way and broadcast channels," *Inf. Contr.*, vol. 46, pp. 1–15, 1980.
- [6] C. Suh and D. N. Tse, "Feedback capacity of the Gaussian interference channel to within 2 bits," *IEEE Trans. Inf. Theory*, vol. 57, pp. 2667–2685, May 2011.
- [7] S. E. Yang and D. Tuninetti, "Interference channel with generalized feedback (a.k.a. with source cooperation): Part i: Achievable region," *IEEE Trans. Inf. Theory*, vol. 57, pp. 2686–2710, 2011.
- [8] T. M. Cover and A. El Gamal, "Capacity theorems for the relay channel," *IEEE Trans. Inf. Theory*, vol. IT-25, pp. 572–584, Sep. 1979.
- [9] A. D. Wyner and J. Ziv, "The rate-distortion function for source coding with side information at the decoder," *IEEE Trans. Inf. Theory*, vol. 22, pp. 1–10, Jan. 1976.
- [10] S. H. Lim, Y.-H. Kim, A. E. Gamal, and S.-Y. Chung, "Noisy network coding," *IEEE Trans. Inf. Theory*, vol. 57, pp. 3132–3152, May 2011.
- [11] A. Avestimeher, S. Diggavi, and D. Tse, "Wireless network information flow: a deterministic approach," *IEEE Trans. Inf. Theory*, vol. 57, pp. 1872–1905, April 2011.
- [12] C. Karakus, I.-H. Wang, and S. Diggavi, "Interference channel with intermittent feedback," in *Proc. IEEE Int. Symp. Information Theory*, Istanbul, Turkey, Jul. 2013, pp. 26–30.
- [13] I.-H. Wang, C. Suh, S. Diggavi, and P. Viswanath, "Bursty interference channel with feedback," in *Proc. IEEE Int. Symp. Information Theory*, Istanbul, Turkey, Jul. 2013, pp. 21–25.
- [14] A. Khisti and A. Lapidoth, "Multiple access channel with intermittent feedback and side information," in *Proc. IEEE Int. Symp. Information Theory*, Istanbul, Turkey, Jul. 2013, pp. 2631–2635.
- [15] A. Zaidi, "On interference channels with generalized and intermittent feedback," *Draft available at http://www-syscom.univ-mlv.fr/~zaidi/publications/proofs-isit2014.pdf*, 2014.
- [16] A. E. Gamal and Y.-H. Kim, *Network information theory*. Cambridge University Press, 2011.